**Special tools required:**

- 11 2 170

(clutch removed)

Lock flywheel with special tool 11 2 170 .

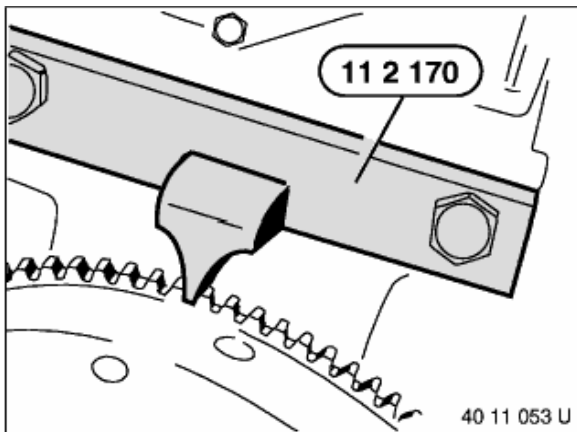

Unfasten screws and remove flywheel.

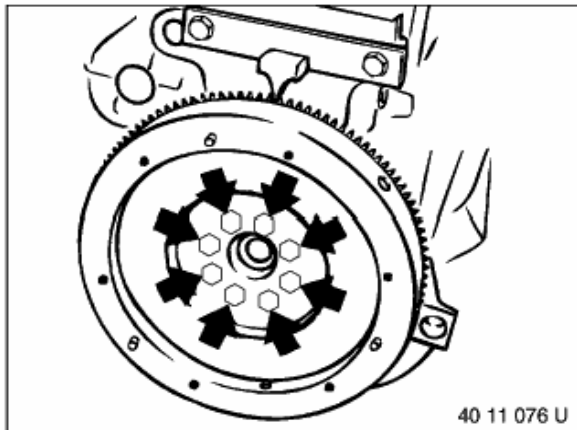

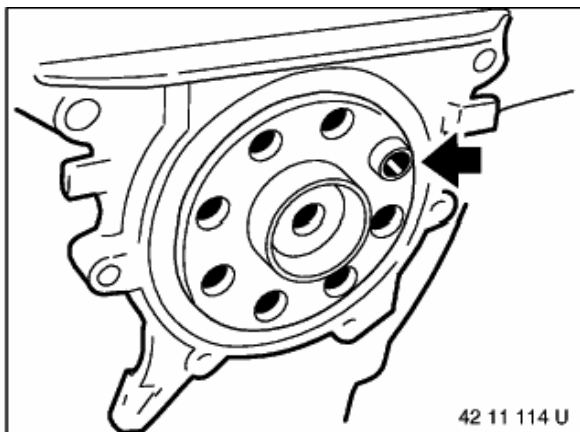

Installation:

Check dowel sleeve for damage and correct installation position.

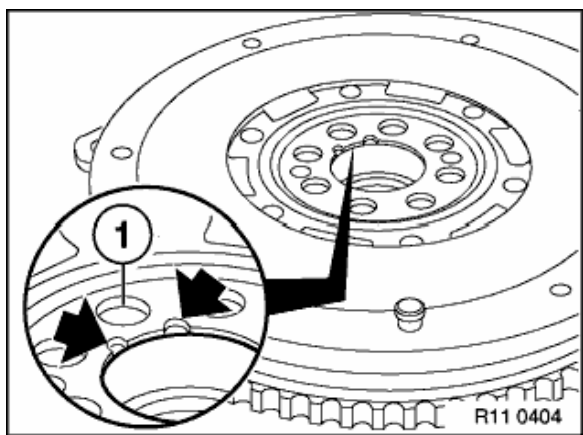

Installation:

Position of dowel sleeve (1) in dual-mass flywheel is identified by two notches next to associated bolt hole.

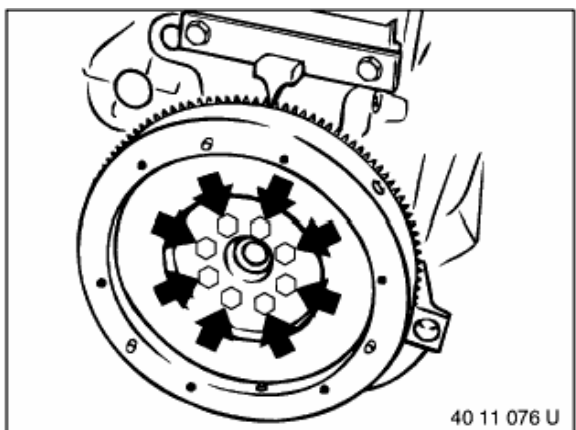

Installation:

Clean thread and install new micro-encapsulated screws.
Tightening torque 11 22 1AZ.