

*Note:*

When work has been completed, actuate brake pedal several times to ensure that brake pads make firm contact with brake disks.

When installing new brake linings on the front axle and simultaneously replacing the brake linings on the rear axle, check the brake-fluid level and top up to the "MAX" marking if necessary.

Remove wheels,  
refer to 36 10 300.

Lift out retaining spring (1).

Left:

Disconnect plug connection for brake lining sensor.

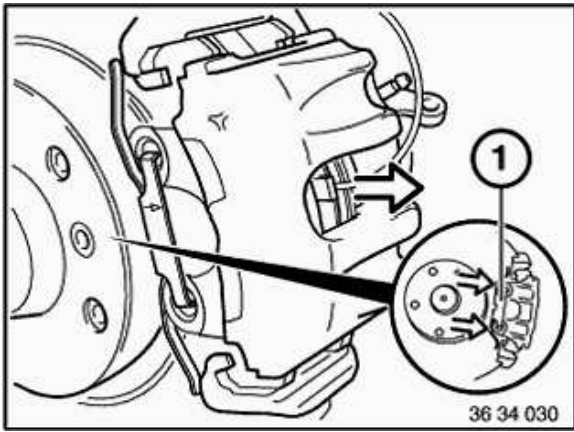

Remove plastic plugs (2).

Lift brake hose out of bracket.

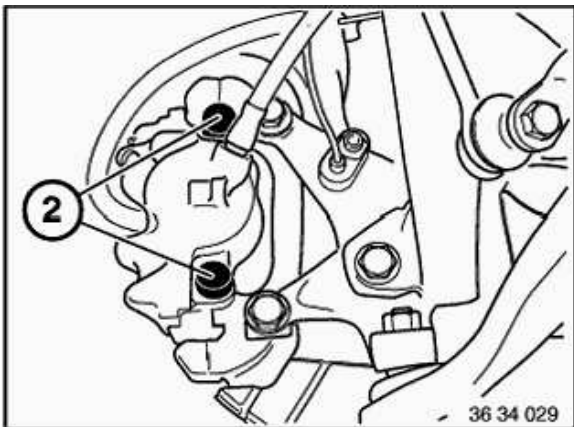

Unfasten guide screws (1) and lift out brake caliper towards rear of vehicle.

*Installation:*

Only clean guide screws; do not grease.

Check threads.

Replace all guide screws which are not in perfect condition.

Tightening torque, refer to Technical Data 34 11 3AZ

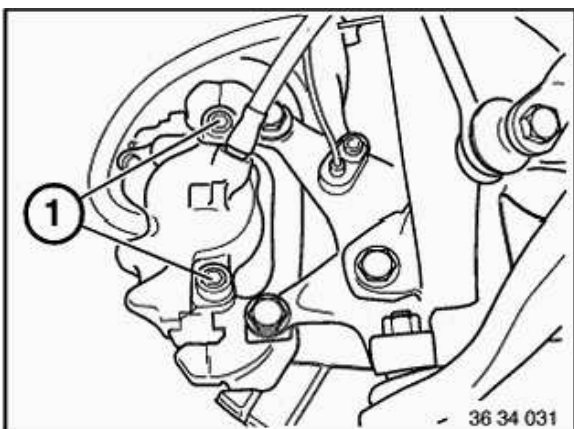

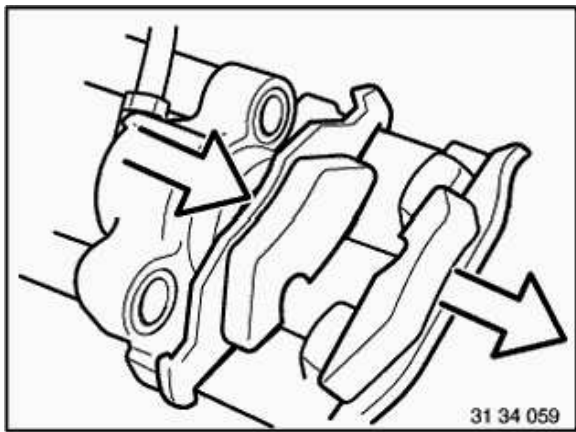

Remove outer brake lining.  
 Inner brake lining is located with its spring in the piston.

*Caution!*

Mark any worn brake linings.

In the event of one-sided brake lining wear, do not change brake linings round.

New brake linings should only be installed if the brake disk thickness is greater than or equal to minimum thickness (MIN TH),

refer to Technical Data

Note residual lining thickness of brake linings,

refer to Technical Data

Clean brake linings.

Do not grease brake lining back plate.

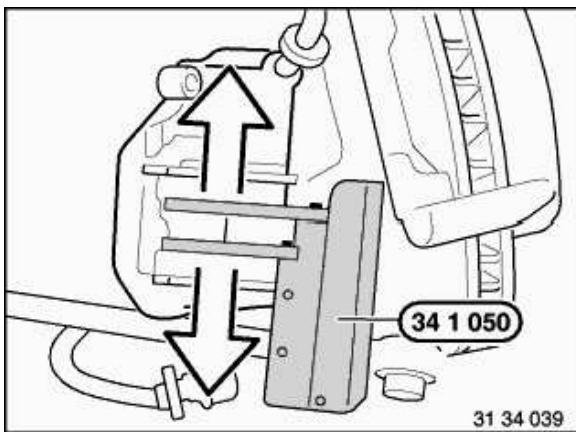

*Installation:*

Turn piston fully back with special tool 34 1 050.

*Caution!*

When pressing down piston, note brake fluid level in expansion tank.

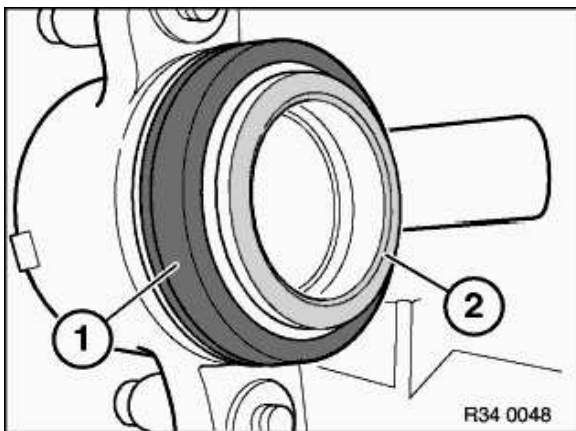

Check dust sleeve (1) for damage and replace if necessary.

Clean contact surfaces (2) of brake piston and coat with a thin layer of anti-squeak compound.

Anti-squeak compound, refer to BMW Service Operating Fluids.

*Caution!*

Dust sleeve must not come into contact with anti-squeak compound as it may cause dust sleeve to expand.

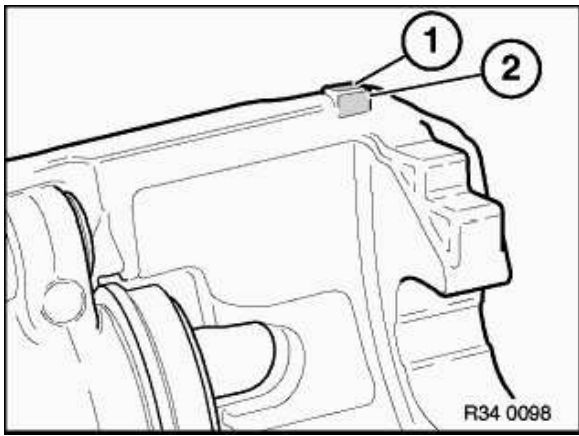

Clean contact surfaces (1 - 2) of brake-lining tee heads on brake caliper and thinly coat with anti-squeak compound.  
Anti-squeak compound, refer to BMW Service Operating Fluids.

*Note:*

Grease contact surfaces on brake caliper at top and bottom.

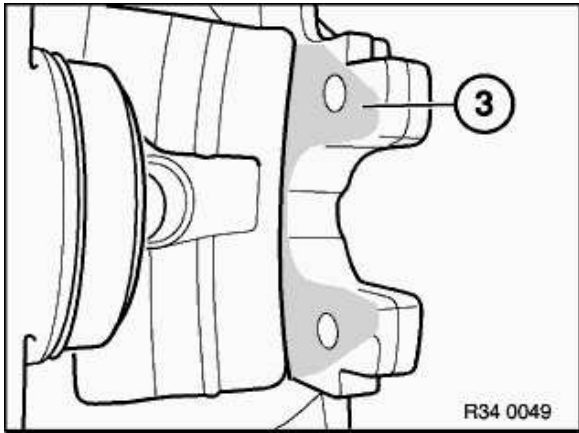

Clean contact surface (3) of brake linings on brake caliper and thinly coat with anti-squeak compound.  
Anti-squeak compound, refer to BMW Service Operating Fluids.

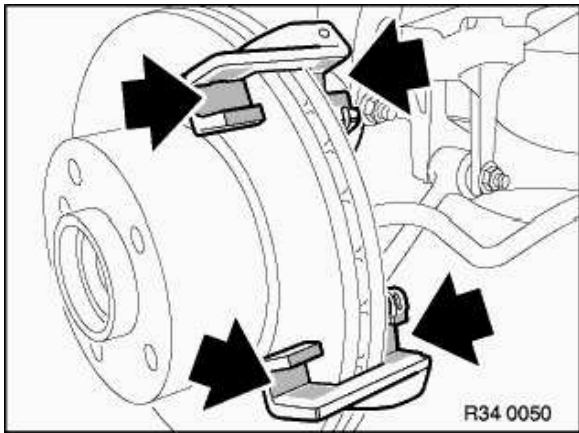

Clean hammer head guides on brake caliper holders and coat with a thin layer of anti-squeak compound.  
Anti-squeak compound, refer to BMW Service Operating Fluids.