



Important! Safety instructions

Use of the navigation unit is only permitted if the traffic conditions are suitable and you are absolutely sure that no risk, obstruction or inconvenience will be incurred to you, your passengers or other road users.

The requirements of the Road Traffic Regulations apply at all times. The destination must only be entered when the vehicle is stationary.

The navigation system serves solely as an aid to navigation. It neither releases the driver from his duty to drive carefully in road traffic, nor does it take the place of his own ability to make judgement. It is possible that inaccurate or incorrect instructions are given due to changing traffic conditions or varying data. The actual road signs and traffic regulations must therefore always be observed. In particular, the navigation system cannot be used as an aid to orientation when visibility is poor.

The unit must only be used for its intended purpose. The volume of the car radio/navigation system must be adjusted so that external noise is still audible.

Switch off the unit immediately if a fault occurs (e.g. emission of smoke or odours).

In the interest of safety, the unit must only be opened by a specialist. Please refer to your dealer for repair.

Contents

Contents	76	Route guidance calculation	95
Arrangement of controls	78	Stopover	96
Anti-theft system	79	Traffic jam function	97
Entering the code number	79	Cancelling route guidance	98
Removing the portable panel	80	Notes on route guidance	99
Inserting portable panel	80	Dynamic navigation with TMC	101
General operation	81	Information during route guidance	104
Switch on / off	81	Destination memory	107
Adjusting the volume	81	Special destinations	107
Activating the tone menu	81	Points of interest (P.O.I.) CD	110
Setting the bass	81	System settings	112
Setting the treble	81	Radio mode	118
Fader	82	Switching on radio mode	118
Setting the balance	82	Switching on radio menu mode	118
Linear setting	82	Selecting the FM waveband	118
Switching loudness on / off	82	Selecting the AM waveband	118
Setting the subwoofer or centre speaker volume	82	Setting options for transmitter selection	118
Navigation operation	83	Dynamic autostore (FM DAS)	119
What is navigation?	83	FM DAS transmitter search	119
Safety instructions	83	Transmitter search MW, LW, SW	119
Digitised area	83	Scan search	120
General notes	84	Programme filtering for FM DAS	120
Selecting navigation	85	Programme type selection (PTY)	120
Main navigation menu	85	Switching PTY display on / off	121
Entering destination	86	Requesting/storing FM transmitters	121
Route menu	92	Requesting/storing MW, LW, SW transmitters	121
Storing a specified destination in the destination memory	94	MW, LW autostore	122
		FM manual tuning	122
		MW, LW, SW manual tuning	122

Regionalisation	123	Naming a CD	133
Switching regionalisation on/off	123	CD filter function	134
Switching frequency display on / off	123	User menu	135
Switching radio text display on / off	124	Requesting/quitting user menu	135
Traffic Programme (TP)	124	GAL setting (Gal)	135
Activating/quitting the TP menu	125	Telephone mute characteristics (Tel)	136
Switching TP on/off	125	Display colour setting (Col)	136
Selecting automatic tracking	126	Display setting (Lcd)	136
Selecting / deleting direct programming	126	Setting reception optimisation (M/S)	137
Switching mute on/off	126	LED setting (Led)	137
Interrupting TP announcements	127	Setting navigation announcements (Nav)	137
TP announcement volume	127	AUX input (Aux)	138
Switching TMC on/off	127	Compass display (Cmp)	138
Display for TMC stations	128	Signal tone volume (BeV)	139
Telephone mute function	128	Service menu	140
CD operation	129	Requesting /quitting the service menu	140
Compact Disc (CD) instructions	129	Triggering reset	140
Inserting / ejecting CDs	129	Connection instructions	141
Track skip - forwards / backwards	130	Removal / installation guide	142
Scan search	130	General instructions	144
Fast forward / rewind	130	RDS SYSTEM	144
Random play	130	DAS Seek Qual. plane	144
Repeating a track	131	DAS Seek Name plane	144
Number of tracks and total playing time	131	Stations RDS plane	144
Temperature protection circuit	131	Stations Fix plane	144
CD changer operation	132	PTY (Programme Type)	145
Operational readiness of CD changer	132	Technical data	146
CD magazine - load / unload	132	NOTICE	147
Playing CDs	132		

Arrangement of controls

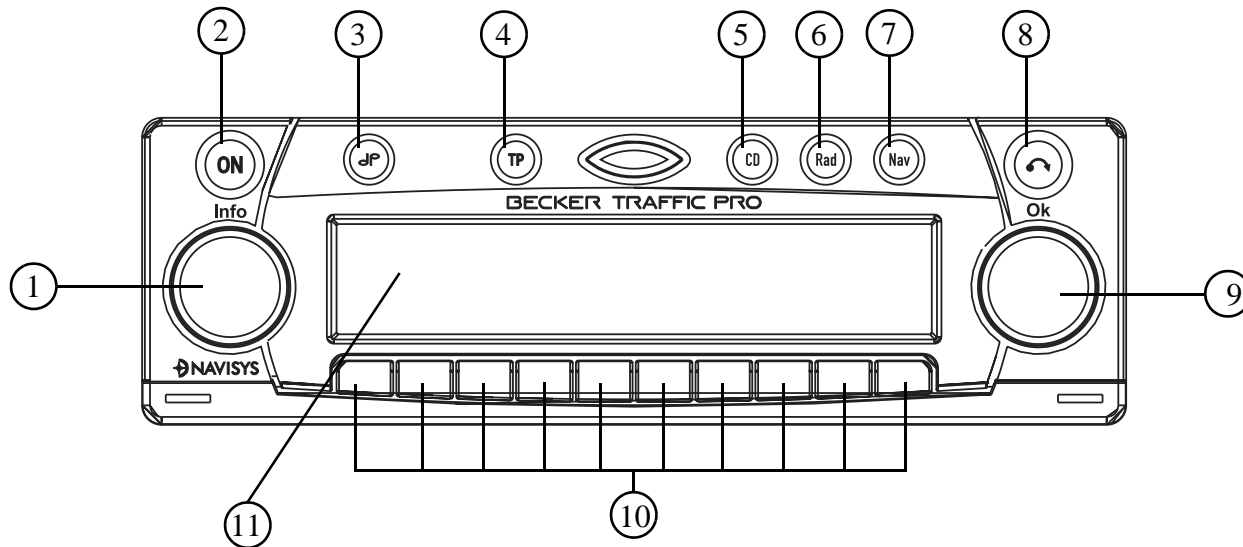

1 Left rotary control ● (Info)

2 On / off switch (ON)

3 Tone button (🔊)

4 Traffic programme button (TP)

5 Select CD mode (CD)

6 Select radio mode (Rad)

7 Select navigation mode (Nav)

8 CD eject button (🔙)

9 Right rotary control ● (Ok)

10 Multifunction buttons

11 Display

Entering the code number

If the car radio is disconnected from the power supply, it is theft-protected upon reconnection. After switching on via the **ON** button, the prompt Enter Code Number, is displayed.

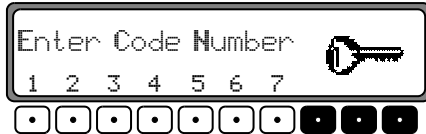

The five-digit code must then be entered using the multifunction buttons "1 - 7".

Example: Code number 15372 (the code number can be found on the enclosed CODE CARD).

Enter code number using the multifunction buttons.
The unit automatically switches when the fifth digit is entered and all other digits have been entered correctly.

Note: It is essential that the CODE CARD be kept in a safe place outside the vehicle. Thus, illegal use is not possible. The sticker provided should be attached to the inside of the vehicle windscreen/window.

If an incorrect code number is entered, the prompt CODE is displayed again. After entering an incorrect code three times WAIT is displayed and the unit is disabled for approx. 60 minutes.

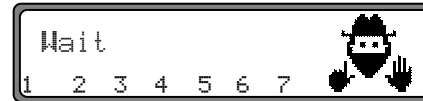

Three further incorrect entries block the unit for another 60 minutes.

Attention : The disabling period functions only with the unit switched on.

Anti-theft system

Removing the portable panel

As an effective anti-theft device, the portable panel (A) can be removed from the unit.

Press  button briefly (storage medium remains in the unit). The display folds forwards.

The portable component can then be pulled out.

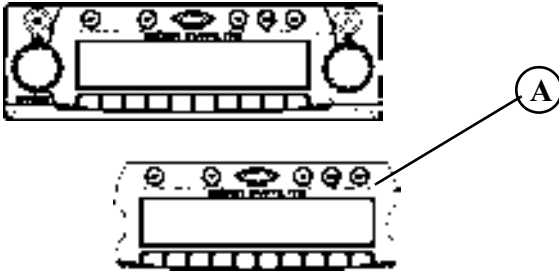

The volume is limited to a maximum value after the display has been folded down. After 20 seconds an audible signal indicates that the control component is folded down. The unit then switches off automatically.

Note: For safety reasons, it is not permitted to leave the portable panel open when driving.

Attention : Please insert the portable panel in the accompanying protective cover after removal.

Do not touch the metal contacts on the portable panel or on the radio.

Inserting portable panel

Insert the portable panel in the lower left catch and then engage it in the lower right catch. Then fold up the portable panel and engage it in the upper catches.

Alternately, position portable panel directly over all four catches and press in firmly to engage.

For correct functioning, ensure that the portable panel is firmly engaged in all four catches.

If a new portable panel or one from another unit is utilised, the code number must be entered, as previously described, in order to activate the unit.

Switch on / off

Press **ON** button.

Additional options for switching on / off: Via ignition. In order to switch on via the ignition, the unit must have been switched off previously via the ignition. After switching off the ignition, the unit can be prevented from switching off by pressing the **ON** button within 3 seconds.

Note: With the ignition switched off, the unit can also be switched on via the **ON** button. The unit switches off automatically after 1 hour.

Adjusting the volume

Turn the left rotary control . The volume is increased or decreased.

Activating the tone menu

Press  button. The tone menu is activated. The following functions can be requested: **Bas** (Bass), **Trb** (Treble), **Fad** (Fader), **Bal** (Balance), **Flt** (Linear setting) **Sub** (Subwoofer) and **Ldn** (Loudness).



Settings for the bass, treble, fader, balance and loudness are stored separately for wavebands MW, LW, SW, FM, for traffic announcements, navigation messages, telephone operation, CD and CDC/AUX operation.

Setting the bass

Press the  button and then the multifunction button **Bas**.



Set the desired bass level using the right rotary control .

Setting the treble

Press the  button and then the multifunction button **Trb**.

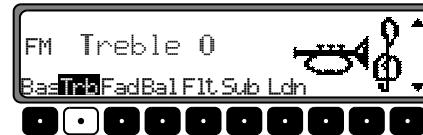

Set the desired treble level using the right rotary control .

General operation

Fader

Press the  button and then the multifunction button **Fad**.



Use the right rotary control  for the desired fader setting.

Setting the balance

Press the  button and then the multifunction button **Bal**.



Set the desired balance level using the right rotary control .

Linear setting

Briefly press the  button.



Press the multifunction button **Fit** - Tone flat is displayed. By pressing the multifunction button **Fit** again the tone settings for the currently selected signal source (e.g. FM) are set to an average value.

Switching loudness on / off

Press the  button and then the multifunction button **Ldn**.

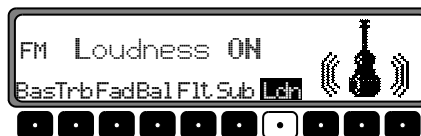

Using the multifunction button **Ldn** you can select either loudness on (ON) or loudness off (OFF).

Loudness is switched off in MW, LW and SW wavebands.

Setting the subwoofer or centre speaker volume

Press the multifunction button **Sub**.



Use the right rotary control  to set the desired subwoofer volume level.

What is navigation?

The term "navigation" (lat. navigare = to travel by sea) is generally understood to mean the location of a vehicle, the determination of the direction and distance from the desired destination and the required route. Stars, prominent landmarks, compasses and satellites etc. are used as navigation tools.

With the Becker TrafficPro, the location is determined via the GPS receiver (GPS = Global Positioning System). The direction and distance from the destination is determined using a digital street map, a navigation computer and sensors. A speedometer and reverse signal are additionally used to calculate the route.

For safety reasons, route guidance follows predominantly in spoken form supported by a direction indicator on the display.

Safety instructions

- The requirements of the Road Traffic Regulations (RTR) apply.
- Observation of traffic signs and local traffic regulations always takes priority.
- Traffic guidance is restricted to passenger vehicles. Special driving recommendations and regulations for other vehicles (e.g. commercial vehicles) are not taken into account.
- The destination must only be entered when the vehicle is stationary.

Digitised area

The navigation CD provided contains a digitised street map. Motorways, federal and regional roads, as well as district roads are detailed in this street map. Larger cities and boroughs are completely covered. The regional and unclassified roads or access roads and the town centre for smaller towns and boroughs are included.

One way streets, pedestrian zones, turn bans and other traffic regulations are taken into account as far as possible. There may be discrepancies between the data on the navigation CD and the actual local situation, due to permanent changes to road systems and their traffic regulations.

Navigation operation

General notes

- During navigation mode, radio or CD can still be heard. The distance to the next announcement and, depending on the setting made in “Setting the time display” on page 117, the estimated time of arrival, the current time or the remaining travel time are displayed at the right of the display.
- The unit can be switched to radio mode when route guidance is in operation by pressing the **Rad** button. Press the **CD** button to switch to CD mode. The navigation menu is automatically displayed when navigation announcements are given.
- When entering the address, only those letters, digits and symbols which are relevant for the address are displayed. The entries are automatically completed. Spaces (e.g. in Bad Abbach) must be entered using the underline symbol. Letters, numbers and symbols can be selected via the multifunction buttons **1** to **9**. The individual symbols can be selected by pressing the relevant multifunction buttons repeatedly. Selection can also be made using the right rotary control **➤**, as described later in this guide.
- **Nav** quits the current menu and displays the previous menu.
- The route is recalculated by the system if deviation from the route is made.
- Press the left rotary control **⦿** to hear the current navigation announcement.
- During the navigation announcement, adjustment can be made to the volume using the left rotary control **⦿** and to the tone by pressing the **🔊** button (see page 81).
- By briefly pressing the left rotary control **⦿** additional information can be requested during route guidance or the current position when route guidance is not active. See “Information during route guidance” on page 104.
- The current navigation announcement is interrupted by pressing the left rotary control **⦿**.
- If the left rotary control **⦿** is pressed for longer than 2 seconds during a navigation announcement, the navigation announcement switches off and route guidance continues via display only. By briefly pressing the left rotary control **⦿** the navigation announcements are switched on again.
- The scroll marks **▲** and **▼** indicate a selection list which can be scrolled through using the right rotary control **➤**. Each entry in the list shown in capital letters can be selected by pressing the right rotary control **➤**.

Selecting navigation

Press **Nav** multifunction button.

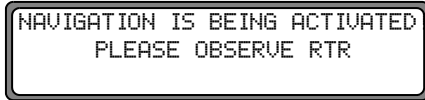

The main navigation menu appears after this display.

- Note:** The navigation CD must be loaded when starting navigation operation for the first time. If the navigation system has not yet been calibrated, a calibration journey is prompted (see Installation Guide). A navigation CD with the data for the destination country is required for navigation operation. The navigation CD must be inserted to start the route calculation. During the calculation, the prompt **CD** flashes on the display. Once the calculation has been completed, the prompt **CD** extinguishes, the navigation CD can be removed and an audio CD can be inserted. When entering destinations, driving off should be delayed until the prompt **CD** disappears.

Main navigation menu



Selection from



- DESTINATION,
- DEST. MEMORY,
- P.O.I.,
- LAST DESTINATIONS,

can be made by turning the right rotary control **➤**, and confirmed by pressing the right rotary control **⬤**.

- **DESTINATION**
accesses the entry menu for the destination. See "Entering destination" on page 86.
- **DEST. MEMORY**
contains destinations which have been stored previously. See "Destination memory" on page 107.
- **P.O.I**
Menu for the selection of special local and interregional destinations and special destinations nearby. Special destinations are e.g. petrol stations, airports or hospitals See "Special destinations" on page 107.

Navigation operation

- **LAST DESTINATIONS**

A list of the last 50 destinations is displayed. The desired destination can be selected using the right rotary control . Before confirming with the right rotary control , details of the destination can be requested by pressing the left rotary control . Stopovers are not stored as last destinations.

Entering destination

Select **DESTINATION** in the main navigation menu using the right rotary control  and press to confirm.

Selecting the country



If your destination lies in another country, select **GERMANY** using the right rotary control  and press to confirm.



Select the country using the right rotary control  and press to confirm.

Note: We recommend the selection of a stopover (page 96) at the half-way point to the destination.

Entering the destination





The last location entered is displayed.

If you want to enter a destination in the displayed location, you can select ROAD or CENTRE immediately.

If your destination lies in another location, select the location using the right rotary control  and press to confirm.





Select the letters one after the other by turning the right rotary control  and press to confirm. The enlarged selected letter appears at the right of the display.

Using the multifunction button  the last confirmed letter is deleted.

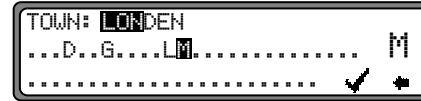
The complete entry is deleted if the multifunction button  is pressed for more than 2 seconds.



Letters which are already entered are displayed inversely. For the purpose of support, the existing entry is displayed at the next place-name to be reached. The unit offers only the possible remaining letters for selection. If no other entries are available, the unit completes the place-name automatically.

To accept the entry, press and hold the right rotary control  for more than 2 seconds or select the small tick  and briefly press the right rotary control .

If the complete place-name was previously entered or was automatically completed, the program switches to either place-distinguishing list or to road or centre entry.

If no roads and only the centre can be selected in the location entered, the program switches directly to route menu.

If an incomplete location entry was confirmed, the place selection list is displayed.

Navigation operation

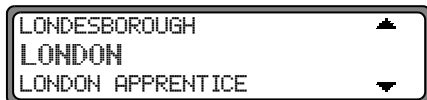

The place nearest to the entry appears in capital letters in the place selection list.

The scroll marks indicate that more places are available for selection in alphabetical order.

Select by turning and confirm by pressing the right rotary control **⬤**. (See "General notes" on page 84.)

If the entry is unequivocal, the program switches to road or centre entry. If no roads and only the centre can be selected in the location entered, the program switches directly to route menu.

The place-distinguishing list is displayed if the selection is ambiguous.

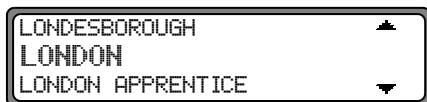

Select the required place using the right rotary control **⬤** and press to confirm.

The program switches to road or centre entry.

If no roads and only the centre can be selected in the location entered, the program switches directly to route menu.

Selecting destination via post code

The destination can also be selected via the town's post code.



Select the destination's POST CODE by turning the right rotary control **⬤** and press to confirm the selection.

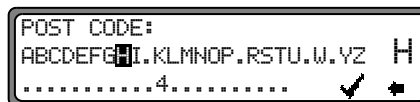

Using the right rotary control **⬤**, enter the post code for the destination and press for more than 2 seconds to confirm the entry. To confirm, the small tick **✓** can also be selected and the right rotary control **⬤** briefly pressed.

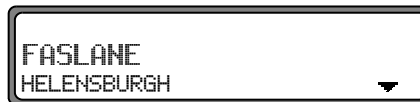

The display then shows either the destination corresponding to the post code or, if the post code is shared among several towns, a list containing these towns.

Select the required location using the right rotary control  and press to confirm.

If more than 20 locations share the same post code, the display will show the location input menu instead of the above-mentioned list. In that case, the location name is to be entered as described in “Entering the destination” on page 87.

The program returns to road or centre entry. If there are no streets in the selected town or only the centre can be selected, the unit will switch directly to the route menu.

Entering the destination road



Using the right rotary control , select ROAD and press to confirm.

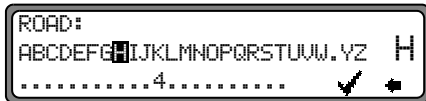

Select the letters one after the other by turning the right rotary control  and press to confirm. The enlarged selected letter appears at the right of the display.



Using the multifunction button  the last confirmed letter is deleted.

The complete entry is deleted if the multifunction button  is pressed for more than 2 seconds.



Letters which are already entered are displayed inversely. For the purpose of support, the existing entry is displayed at the next road to be reached. The unit offers only the possible remaining letters for selection.

If no other entries are available, the unit completes the road-name.

To accept the entry, press and hold the right rotary control  for more than 2 seconds or select the small tick  and briefly press the right rotary control .

If the complete road-name was previously entered or was automatically completed, the program switches to either road-distinguishing list or to route menu.

If an incomplete location entry was confirmed, the road selection list is displayed.



Navigation operation

The road nearest to the entry appears in capital letters in the road selection list.

The scroll marks indicate that more roads are available for selection in alphabetical order.

Select the road by turning the right rotary control ● and press to confirm.

If the entry is unequivocal, the program switches to route menu.

The road-distinguishing list is displayed if the selection is ambiguous.

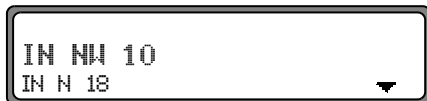

Select the required place using the right rotary control ● and press to confirm.

The program switches to route menu.

Entering the destination centre



Using the right rotary control ●, select CENTRE and press to confirm.

If the place selected only has one centre, the program switches immediately to route menu.

If the number of centres is less than 10, the centre list is displayed.

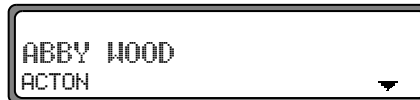

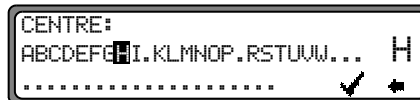

Select the centre by turning the right rotary control ● and press to confirm.

If the number of centres is greater than 9, the program switches to centre entry.





Select the letters one after the other by turning the right rotary control ● and press to confirm. The enlarged selected letter appears at the right of the display.

Using the multifunction button  the last confirmed letter is deleted.

The complete entry is deleted if the multifunction button  is pressed for more than 2 seconds.



Letters which are already entered are displayed inversely. For the purpose of support, the existing entry is displayed at the next centre to be reached. The unit offers only the possible remaining letters for selection. If no other entries are available, the unit completes the centre-name.

To accept the entry, press and hold the right rotary control  for more than 2 seconds or select the small tick  and briefly press the right rotary control .

If the complete centre-name was previously entered or was automatically completed, the program switches to route menu.

The program switches to the centre list if the selection is ambiguous.



The centre nearest to the entry appears in capital letters in the centre list.

The scroll mark indicates that more centres are available for selection in alphabetical order.

Select the centre by turning the right rotary control  and press to confirm.

The program switches to the route menu.

Note: A list of possible centres is displayed immediately by pressing the right rotary control  for more than 2 seconds without having selected any letters.

Navigation operation

Route menu



Selection from

- SAVE DESTINATION,
- START-FAST R., (START-SHORT R. or START-DYN. R.)
- HOUSE NUMBER,
- CROSSING
- ROUTE SETTING

can be made by turning, and confirmed by pressing the right rotary control .



- **SAVE DESTINATION**
accesses the entry menu for the destination memory (page 94).
- **START-FAST R., START-SHORT R. or START-DYN. R.**
Starts route guidance. Simultaneously, a prompt appears indicating the currently selected route option (-SHORT R. for a short route, -FAST R. for a fast route and -DYN. R. for a dynamic route).
- **HOUSE NUMBER**
The house number in the specified destination road can be entered here.
This function is only available if this information is stored on the navigation CD.

- **CROSSING**
An intersecting road can be defined as the destination here.
This function is only available if this information is stored on the navigation CD.
- **ROUTE SETTINGS**
Specifications such as quick route, short route, dynamic route, motorway, ferries and toll roads can be selected here.

Entering the house number for the destination road

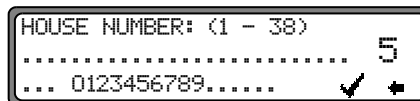
Using the right rotary control  select **HOUSE NUMBER** in the route menu and press to confirm.



Using the right rotary control , enter the house number for the destination road and press for more than 2 seconds to confirm the entry. To confirm, the small tick  can also be selected and the right rotary control  briefly pressed.
Due to the system characteristics, route guidance continues only in the area of the house number specified.



Select **START-** to start route guidance.

Select **SAVE DESTINATION** to jump to the destination memory menu.

Select **ROUTE SETTINGS** to access the possible route settings.

Select by turning the right rotary control  and press to confirm the selection.

Select the intersection for the destination road

Using the right rotary control , select **CROSSING** in the route menu and press to confirm.



Select the intersection for the destination road by turning the right rotary control  and press to confirm.



Select **START-** to start route guidance.

Select **SAVE DESTINATION** to jump to the destination memory menu.

Select **ROUTE SETTINGS** to access the possible route settings.

Select by turning the right rotary control  and press to confirm the selection.

Selecting the route settings

Using the right rotary control , select **ROUTE SETTINGS** in the route menu and press to confirm.



- **FAST ROUTE**
If selected, the program calculates the shortest possible journey time.
- **SHORT ROUTE**
If selected, the program calculates the shortest possible distance.

Note: The setting "SHORT ROUTE" is often recommended for larger cities or conurbations.

- **DYNAMIC ROUTE**
Dynamic route guidance is used to calculate the route, taking current traffic announcements into account.

Note: Can only be selected if TMC has been switched on or is currently switched on. See "Switching TMC on/off" on page 127.

If dynamic route guidance has been activated, the routes are calculated using the "fast route" setting.



Navigation operation

Further information under “Dynamic navigation with TMC” on page 101.

- **RESTRICTIONS**

Provides options for avoiding motorways, ferries or toll roads.



Selection can be made by turning the right rotary control , and settings can be changed by pressing the right rotary control .

Press the control for more than 2 seconds to accept all settings and quit the menu.

Note: Routes without motorways can only be calculated for short distances (up to 200 km).



Storing a specified destination in the destination memory

It is not absolutely necessary to store a destination in the destination memory for route guidance. It saves repeated manual entry, if the destination is required at a later date.



Select **SAVE DESTINATION** in the route menu and press the right rotary control  to confirm.



Any name of your choice consisting of up to 20 characters can be entered for the specified destination and then automatically stored in the destination memory after pressing the right rotary control  for more than 2 seconds. See “Destination memory” on page 107.

To store, the small tick  can also be selected and the right rotary control  briefly pressed.

If you do not wish to enter a name of your choice, press and hold the right rotary control  for more than 2 seconds to store the address as previously entered in the destination memory.

The last destination entered can be filed at any position by turning the right rotary control . The memory position is confirmed by briefly pressing the right rotary control .

A total of 50 destinations can be stored.



For final storage in the destination memory, either route guidance must be started or the program must be switched to new destination entry by selection of **NEW DEST.**.

Deleting stored destinations

Select destination memory (see page 107).



Select the destination to be deleted using the right rotary control  and press the **DEL** multifunction button.

Destination memory full



Occurs when the destination memory is full. Select either **DELETE** (to jump to the destination memory in order to delete a destination) or **BACK** (to cancel saving).

Route guidance calculation



The message "Calculating route" indicates that the distance is being calculated, which may take several seconds. After the first route guidance announcement, the prompt **CD** flashes on the display until the route has been completely calculated. When entering a destination, driving off should be delayed until **CD** no longer flashes.

Recalculating the route.



If the current route is not followed due to road blocks, diversions, unintentional driving in the wrong direction or failing to observe the recommendations, the system immediately calculates a new route. During this recalculation, **NEW ROUTE** is displayed.

Navigation operation

Stopover

This function enables a stopover to be entered when route guidance is active.

Entering a stopover



Press the multifunction button .





Using the right rotary control , make a selection and press to confirm.

- **DEST. MEMORY**
(see page 107) Select the stopover from the destination memory.

- **DESTINATION**
(see page 86) allows entry of a stopover with the precise specification of the address.
- **P.O.I**
(see page 107) enables the selection of special destinations as stopovers via **LOCAL AREA**, **NEARBY DESTINATION** and **TOWN/COUNTRY**, e.g. petrol stations or airports.

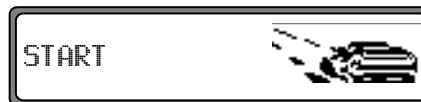
Starting route guidance to a stopover



To start route guidance to the stopover, press the right rotary control .

The route is calculated and route guidance begins.

Note: The  symbol is displayed inversely during route guidance to a stopover.

Deleting a stopover



Press the multifunction button .



To delete the stopover, press the right rotary control  within 8 seconds.

Stopover reached

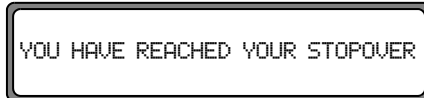

Route guidance to the final destination automatically starts following the message YOU HAVE REACHED YOUR STOPOVER.

Traffic jam function

This function allows you to block the approaching route sections as from the next junction and calculate a bypass route when a traffic jam or road block is directly ahead.

Entering the length of the traffic jam



Press the multifunction button .



Using the right rotary control , select the length of the traffic jam and press to confirm.



 is displayed inversely and the route is recalculated.

Navigation operation

Delete block



Press the multifunction button .



To delete a block, press the right rotary control  within 8 seconds.

Cancelling route guidance

Press  button.

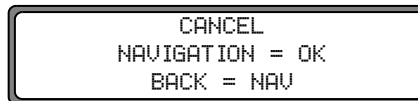

Route guidance is cancelled by pressing the right rotary control  within 8 seconds.

Otherwise, route guidance continues.

Notes on route guidance

After entering the destination (address), the system calculates the route and announces:

"Ready to drive off".

The driving recommendations are given by voice messages and displays on the screen.

By pressing the left rotary control  the current driving recommendation can be repeated.

If the route to be travelled is not clear, e.g. at an intersection where a change in direction is not specified, the direction of travel can be displayed by pressing the right rotary control .

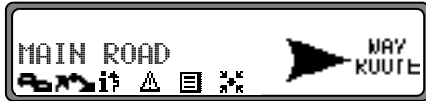

Please follow the direction indicated by the arrow.

The display appears for 8 seconds after pressing the right rotary control .



Danger!

If a driving recommendation contradicts the applicable Road Traffic Regulations (RTR), the RTR is always valid!

For clarification, there follows a selection of examples of possible driving recommendations:

- "Please perform a U-turn if possible".



You are driving in the wrong direction and should turn back at the earliest opportunity.

- "Please turn right after 300 metres".



The arrow indicator  points to the next street into which you should turn.

The progress bar on the right illustrates the distance and the black part decreases as you approach the intersection.

Navigation operation

- "Please follow the road".



This display tells you that you should follow the course of the road.

- "Prepare to turn left" or "Please move into the left-hand lane".



This recommendation prepares you for the next turning to be taken.

However, "move into the left-hand lane" does not mean that you should do so immediately!

Note: At junctions and roundabouts, only the end of the road which is to be passed is displayed.

- "Please leave the roundabout at the third exit on the right".



This display shows you which exit (marked with the arrow) you must take at the roundabout.

- "Now drive straight ahead".



At this point, you must drive straight ahead.

- "Please follow the direction arrows".



This display tells you that you are in a non-digitised street (e.g. car park, garage), which is not included in the digital street map. The arrow indicates the direction of the destination as the crow flies.

- "Keep right after 2 kilometres".

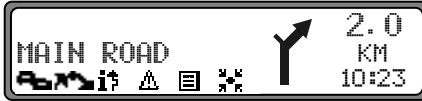

Keeping to the right means that the road forks and you should follow the relevant direction.

- "You have reached your destination".



The destination specified is reached and route guidance is terminated.

Dynamic navigation with TMC

Note: Dynamic route guidance is not possible in all countries.

To use dynamic navigation and the functions described below, TMC must be switched on, as described under "Switching TMC on/off" on page 127.

When any route recalculations are made with active dynamic route guidance, the navigation system may request the Navigation CD (if the Navigation CD is not already inserted).

What is dynamic route guidance?

Dynamic route guidance is used to calculate the route, taking current traffic announcements into account.

The traffic announcements are transmitted by a TMC radio station in addition to the radio programme and are received and analysed by the navigation system. There is no charge for receiving traffic announcements.

Note: Traffic announcements are transmitted by radio stations, therefore we cannot accept any responsibility for the completeness and correctness of the announcements

Navigation operation

Dynamic route guidance

Dynamic route guidance can be started by selecting START-DYN. R. in the route menu.



If dynamic route guidance has been activated, a continuous check is made for the presence of relevant announcements for the selected route. The route is then calculated using the "fast route" option, while taking into account current traffic announcements. If the check determines that a traffic announcement is relevant for the route guidance, then a new route to the destination is calculated automatically by the unit. NEW ROUTE appears on the display. In addition, there is a voice announcement "The route is being recalculated due to current traffic announcements".  is displayed inversely.

Note: If no TMC station was found, then FOR THE TIME BEING TMC RECEPTION IS NOT POSSIBLE is displayed. After a short time, the unit switches back to the route guidance display. If a TMC station still cannot be found after 10 minutes, FOR THE TIME BEING TMC RECEPTION IS NOT POSSIBLE is displayed, accompanied by a brief signal tone.

Your navigation system can receive TMC information, whether a TMC station is selected or not. However, in order to guarantee optimal reception of TMC information, we recommend the selection of a TMC station. During radio operation (FM), a selected TMC station can be recognised by the abbreviation TMC (see page 128).

Displaying traffic information

Current traffic announcements can be displayed in plain text. There are several options for requesting current traffic information.

Traffic information can be requested via the multifunction buttons  and  in the route guidance display and, in the case of inactive route guidance, via the multifunction button  in the information menu.

Route guidance display:



A list of all currently available traffic information is displayed by pressing the multifunction button .

A list of all current traffic information which is relevant for the calculated route is displayed by pressing the multifunction button .

Note: If no traffic information is currently available, NO TRAFFIC MESSAGES RECEIVED is displayed.

Information menu:

For inactive route guidance, the information menu can be requested by pressing the left rotary control .



Press the multifunction button .

A list of currently available traffic information is displayed.

More detailed information on the individual announcements can be requested in the list of current traffic information.



The scroll marks at the right edge of the display indicate that additional traffic information is available.

A selection can be made by turning the right rotary control  and pressing to confirm.

After the desired traffic information has been confirmed, the information is displayed in full. A typical traffic announcement consists of:

- a motorway or road number
- approximate direction information
- detailed location and direction information
- the incident
- the cause, if known



If scroll marks are visible at the right edge of the display, then more than 3 lines are used to display the traffic information. Pressing the  button, switches back to the list of current traffic information.

Navigation operation

Information during route guidance



Press the left rotary control .

The destination, the distance and the estimated time of arrival are displayed.



If a stopover has been specified, the stopover, the distance and the estimated time of arrival are displayed. The main destination can be displayed via the multifunction button .

To return to route guidance, press the left rotary control  again or wait for 8 seconds.

Requesting journey duration and kilometres travelled

Press the left rotary control .



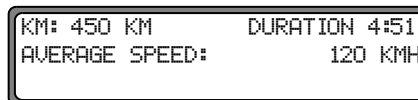

Press multifunction button .



The journey duration, kilometres travelled and the average speed are displayed.



If navigation is not active, the values of the last journey are displayed.

Pressing the right rotary control  for more than 2 seconds resets the values to zero.

Pressing  returns to the navigation display, if navigation is active. If navigation is not active, the display shows the information menu.

Displaying settings



During navigation, press the left rotary control . Press multifunction button .

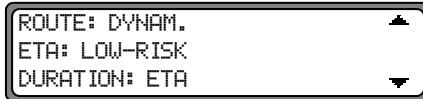



The settings are displayed in a list.

The list can be scrolled by turning the right rotary control . After 8 seconds, the system returns to the navigation display.

Request current time



During route guidance, press the left rotary control . Press multifunction button .



The current time is displayed. After 8 seconds, the system returns to the route guidance display.

Requesting current position

During route guidance, the current position can be requested.

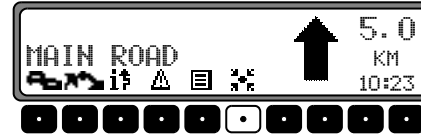



Press the multifunction button .



The current position with road name (if available), degrees of longitude and latitude, altitude above sea level and the number of satellites received are displayed.

Pressing the right rotary control  returns to the navigation display.

By pressing the right rotary control , the program returns to the route guidance display.

For inactive route guidance, the information menu can be requested by pressing the left rotary control .

Navigation operation



Press the multifunction button .



The current position with road name (if available), degrees of longitude and latitude, altitude above sea level and the number of satellites received are displayed.

Pressing the right rotary control  or the  button returns to the information menu.

Requesting the road list

During route guidance, the planned route list can be requested.



Press the multifunction button .



The current road and the road names up to the destination are displayed. The route list can be scrolled by turning the right rotary control .

By pressing the right rotary control , the program returns to the route guidance display.

Note: After destination entry, there is a short delay until the route list is created.

If the vehicle is "off road" at the moment of destination entry, the route list cannot be created until a stored road is reached.

Destination memory

Using the right rotary control ●, select DEST. MEMORY in the main navigation menu and press to confirm.



The destination memory contains personally stored destinations. Once stored, manual entry of the destination is no longer necessary.



Select the destination using the right rotary control ● and press to confirm.

Then start route guidance.

Special destinations

Menu for selecting special destinations from a specified list. Special destinations are e. g. petrol stations, airports or hospitals.



Using the right rotary control ●, select P.O.I. from the main navigation menu and press to confirm.



Using the right rotary control ●, make a selection and confirm.

- Special destinations LOCAL AREA / NEARBY DESTINATION

Special destinations in the current surrounding area of the vehicle or special destinations near the destination can be selected.



Using the right rotary control ●, select a category and press to confirm.

Navigation operation



Destinations are listed according to proximity. The figures in kilometres relate to the direct distance (as the crow flies) between the special destination and the current location.

The arrows following the distance information indicate the distance as the crow flies to the relevant special destination (e.g. ➔ special destination lies in the direction of travel, ➔ special destination lies in the opposite direction to that of travel).

Select the desired destination using the right rotary control ●.

By pressing the left rotary control ●, information on the selected destination is listed (e.g. a hospital).



Confirm the selection using the right rotary control ●.
The system jumps to the route menu.

- Special destinations TOWN / COUNTRY
Special destinations of your choice in countries contained in the navigation CD can be selected.

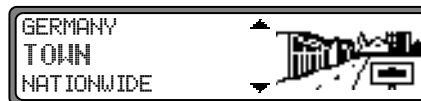

Using the right rotary control ●, select either GERMANY (see page 86), TOWN or NATIONWIDE and press to confirm.

Select TOWN

Special destinations in a specified town can be selected.



Using the right rotary control ●, select the town name and press to confirm.

Then select the town from the town selection list using the right rotary control ● and press again to confirm.



The special destinations for the selected town are displayed. Using the right rotary control , select a category and press to confirm.

A list with special destinations is displayed or if there are more than 9 entries in the list, you will be requested to enter text.

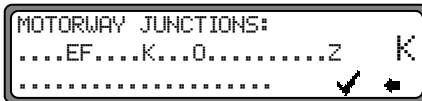

Enter the special destination and confirm. Confirm the special destination in the list displayed by pressing the right rotary control .

The system jumps to the route menu.

Note: A list of possible special destinations is displayed by pressing the right rotary control  for more than 2 seconds without having selected any letters.

Select NATIONWIDE



Using the right rotary control , select a category and press to confirm.

A list with special destinations is displayed or if there are more than 9 entries in the list, you will be requested to enter text.

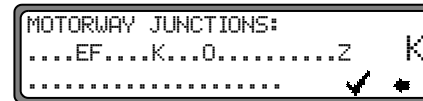

Enter the special destination and confirm. Confirm the special destination in the list displayed by pressing the right rotary control .

The system jumps to the route menu.

Note: A list of possible special destinations is displayed by pressing the right rotary control  for more than 2 seconds without having selected any letters.

Navigation operation

Points of interest (P.O.I.) CD

The following contains the general description of the points of interest (or P.O.I.) CD accompanying the unit.

There are two methods of selecting a point of interest from a points of interest (P.O.I.) CD:

- During active navigation, a point of interest can be selected in the vicinity of the current position or near the entered destination.
- If navigation is not active, points of interest can be selected in the vicinity of the current position.

Insert the desired points of interest CD into the CD slot. After a short time, the following display appears:



Press the right rotary control .

The valid categories for the current points of interest CD are displayed.



The categories and points of interest shown in the illustrations are examples. The actual display is dependent upon the CD used.

Select the desired category with the right rotary control . Then, press the right rotary control to confirm the category.

Note: If the set user language is identical with one of the languages available on the CD, the categories are displayed in this language. If there is no correspondence, the categories are displayed in all available languages. This can be recognised by the country abbreviations in front of the category.

If the points of interest CD is inserted during active navigation, the system requests information on the location of the point of interest (near to destination or in vicinity of current position).

If navigation is not active, this selection is skipped.



With the right rotary control , select either LOCAL AREA or NEAR DESTINATION.



After a short time, the available points of interest for the selected categories are displayed.

The arrows following the distance information indicate the direction of the relevant point of interest (e.g. ↗ point of interest lies in the direction of travel, ↖ point of interest lies in the opposite direction to that of travel).

Then, turn the right rotary control ● to select the desired point of interest. The point of interest is accepted by pressing the rotary control ●.

Before confirming the point of interest, press **Nav** to return to selection of categories in order to select a different point of interest, if required.

Press the left rotary control ● to display information on the point of interest. This information may include prices, location description, general appraisal etc., for the point of interest.



HARHEIMER HOF
60437 FRANKFURT
ALT HARHEIM 11

Pressing **Nav** or pressing the left rotary control ●, returns to the list of points of interest.

Following selection of the point of interest, you are prompted to insert the navigation CD for route calculation.

If the point of interest was selected during active navigation, it will be treated as a stopover.

After a short time, route calculation to the selected point of interest is performed.

Note: If a stopover has already been entered, it will be overwritten by the new point of interest.

In order to cancel navigation to the selected point of interest, you must either cancel navigation or cancel navigation to the stopover, as described in the complete operating guide.

In order to cancel entry of the point of interest from the point of interest (P.O.I.) CD, you must eject the point of interest (P.O.I.) CD by pressing ●.

Terms of licence

You are granted a non-exclusive licence to use the database for your personal purposes, or, where applicable, for internal purposes in your business operations. The present licence does not authorise the granting of sublicenses. Use of the data is only permitted in this specific Becker system. It is forbidden to extract or make further use of significant parts of the database content, or to duplicate, copy, modify, adapt, translate, analyse, decompile or reverse engineer any part thereof. The maximum possible care has been taken in compiling this CD. Nevertheless, some data may be incorrect or outdated. Under no circumstances do we accept any liability.

Navigation operation

System settings

In the main navigation menu, press the **Nav** button.
The system settings menu is requested.



Selection from

TIME,
SAVE POSITION,
GAMES,
LANGUAGE,
ANIMATIONS,
MEASURING UNIT,
ANNOUNCEMENT ETA,
ETA CALCULATION,
DURATION

can be made by turning, and confirmed by pressing the right rotary control **●**.

- **TIME**
The internal system clock can be set to local time.
- **SAVE POSITION**
The current position can be saved and stored in the destination memory.
- **GAMES**
A selection of games is available.

- **LANGUAGE***
Language setting for the navigation system.
The star also enables recognition of the entry for setting a language, even if an unknown language is active.
- **ANIMATIONS**
The display animations can be switched on or off.
- **MEASURING UNIT**
The display units can be changed from metres to yards.
- **ANNOUNCEMENT ETA**
Announcement of the estimated time of arrival can be switched on / off.
- **ETA CALCULATION**
Calculation of the ETA can be influenced.
- **DURATION**
Whether ETA, the current time or the remaining travel time should be displayed on the right side of the display during navigation, is a setting option.

Setting the time

In order to achieve correct navigation on routes requiring guidance under time restrictions and to calculate the estimated time of arrival, it is necessary to set the GMT time transmitted from satellites to the current time zone.



Select **TIME** in the system settings menu and confirm.



Using the multifunction button **24H** the time can be changed from the 24 hour to the 12 hour display.



Using the multifunction buttons **+** or **-** the time is changed every half an hour.

By pressing the right rotary control **OK** or the multifunction button **OK** the time set is accepted.

The program returns to the system settings menu.

Saving the position



Select **SAVE POSITION** in the system settings menu and confirm.

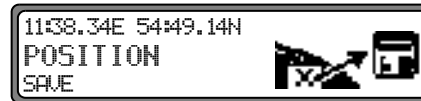

The current co-ordinates (degrees of longitude and latitude) for the position are displayed.

Confirm again by pressing the right rotary control **OK**.



Enter the name of the position.

Press the right rotary control **OK** for more than 2 seconds to confirm the name entered. To confirm, the small tick ✓ can also be marked and the right rotary control **OK** briefly pressed.

The destination memory is automatically requested (see page 107).

Select the desired position in the destination memory using the right rotary control **OK** and press to confirm.

Navigation operation

Requesting the position

Request the destination memory (see page 107) and select destination using the right rotary control .

If the position is outside a digitised area, the driver is guided to the digitised route nearest to the destination. The announcement "Your destination is nearby" is given. The direction of the arrows must be followed in order to reach the destination.

Selecting a game



Select **GAMES** from the system settings menu and confirm.



Select a game using the right rotary control .

Setting the language



Select **LANGUAGE*** in the system settings menu and confirm.



Select the language using the right rotary control . The language selection is accepted by pressing the control and the language is installed.

You can choose either a male or a female voice for certain languages.



Select the voice using the right rotary control . The voice is accepted and installed by pressing the control.



The system returns to the system settings menu after installation.

Animations



Select **ANIMATIONS** in the system settings menu and confirm.



It is possible to select between animations **ON** and **OFF** by briefly pressing the right rotary control . Press and hold the right rotary control  to accept the setting. The system returns to the system settings menu.



Switching announcement of the estimated time of arrival on /off



Select **ANNOUNCEMENT ETA** in the system settings menu and confirm.

ETA stands for **Estimated Time of Arrival**.



It is possible to select between announcement ETA **ON** and **OFF** by briefly pressing the right rotary control . Press and hold the right rotary control  to accept the setting. The system returns to the system settings menu.

Navigation operation

Selecting the measuring unit



Select **MEASURING UNIT** from the system settings menu and confirm.



Select the measuring unit using the right rotary control . The measuring unit is accepted by pressing the control. The system returns to the system settings menu.

Note: **METRIC** indicates calculation in metres.
IMPERIAL indicates calculation in yards.

Influencing the calculation of ETA



Select and confirm **ETA CALCULATION** in the system settings menu.

ETA stands for **Estimated Time of Arrival**.



Use the right rotary control  to select the desired setting.

- **SPORTIV**
With this setting the unit adjusts ETA for faster drivers. An earlier ETA is calculated.
- **NORMAL**
This is the default setting. It offers a sufficiently accurate calculation of ETA for most drivers.
- **LOW-RISK**
With this setting the unit adjusts for drivers who may take longer for the planned journey. This setting could be used, for example, in areas of dense traffic.

Selection is confirmed by pressing the control. The system returns to the system settings menu.

Setting the time display



Select and confirm DURATION in the system settings menu.

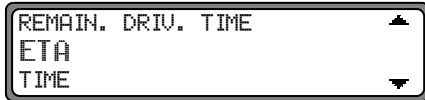

Use the right rotary control  to select the desired setting.

- REMAIN. DRIV. TIME
The display shows the remaining travel time.
- ETA
The display shows the estimated time of arrival.
- TIME
The display shows the current time.

Selection is confirmed by pressing the control.
The system returns to the system settings menu.

Radio mode

Switching on radio mode

Press **Rad** button.

The radio is set to the previously selected waveband.

Switching on radio menu mode

In radio mode, press the **Rad** button.

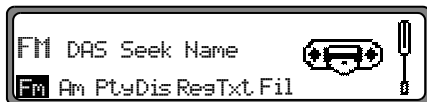

The radio menu mode is switched on and displayed. The unit switches back to radio mode if no button is pressed within the next 8 seconds.

Selecting the FM waveband

In radio menu mode, press the **FM** multifunction button.



The last selected transmitter and plane are displayed.

By pressing several times, the planes DAS Seek Qual., DAS Seek Name, Stations RDS and Stations Fix can be selected.

- DAS Seek Qual. (see also page 144).
- DAS Seek Name (see also page 144)
- Stations RDS (see also page 144)
- Stations Fix (see also page 144)

Selecting the AM waveband

In radio menu mode, press the **Am** multifunction button.



The last selected waveband and transmitter are set.

To select the wavebands MW (med. wave), LW (long wave) and SW (short wave), press the multifunction button **Am** repeatedly until the required waveband is selected.

Setting options for transmitter selection

The desired transmitter can be selected via dynamic autostore (FM), autostore (MW, LW), transmitter search, scan search, manual tuning, and station buttons.

Dynamic autostore (FM DAS)

In radio menu mode, press the **Fm** multifunction button repeatedly until DAS Seek Qual. or DAS Seek Name is displayed.



In FM DAS mode, the receivable transmitters are displayed according to the setting via the multifunction buttons.



Set the desired transmitter by pressing the button directly below the abbreviated station designation. If the selected transmitter broadcasts several programmes/regional programmes, a submenu is automatically displayed to select the desired programme.



If a programme has previously been selected that belongs to the particular transmitter chain, the last stored programme entry will be automatically selected.

The multifunction button **->** indicates that the button can be pressed for displaying and selecting additional transmitters.

To indicate those transmitters not easily identified due to the display of advertisements or news, the abbreviation L-1... L-Z (L = Local) is used. This prevents constant switching in the lower display line. When a transmitter is selected, it is indicated by a star (e.g. L*1).

When using the unit for the first time, or following interruption of the power supply, allow for a brief waiting period so that the receiver can evaluate the transmitter signals. The display will appear incrementally as the evaluation progresses.

FM DAS transmitter search

Turn the right rotary control **●** to the left/right. The radio displays the receivable and identified transmitters in descending/ascending order.

Transmitter search MW, LW, SW

In the desired waveband (MW, LW, SW), turn the right rotary control **●** to the left/right. The radio searches for reception frequencies in descending/ascending order of frequency.

Radio mode

Scan search

In the desired waveband (FM, MW, LW, SW) press the right rotary control ; SC is displayed.



An automatic transmitter search is started. The first run is performed on an insensitive plane, all further runs on a sensitive plane. Receivable transmitters can be heard for 8 seconds. Press the right rotary control  if the received programme should be retained.



Note: For FM DAS, the scan search is performed in alphabetical order.

Programme filtering for FM DAS

You have the option of filtering various stations from the FM DAS transmitter list.

In radio menu mode, press the **Fil** multifunction button.



The individual programmes can be selected using the right rotary control . It is then possible to select between **Play** (programme not filtered) and **skip** (programme filtered out) by pressing the right rotary control .

In order to switch the filter function on or off, repeatedly press the multifunction button **Fil**. The filter function is switched on (Fil on) or off (No Fil).

Programme type selection (PTY)

In radio menu mode, press the **Pty** multifunction button.



Then, using the multifunction button **Pty** select the desired PTY (see also page 145).

Note: Only those PTYs can be selected that are currently available.

Once a PTY has been selected, only those transmitters can be selected in FM DAS mode that are equipped with this PTY. By selecting **NO PTY**, all transmitters will be re-displayed in FM DAS mode.

Switching PTY display on / off

Select radio menu mode.



Using the multifunction button **Dis** select either PTY (PTY display switched on) or Frequency (PTY display switched off).

Requesting/storing FM transmitters

In radio menu mode, use the multifunction button **Fm** to select the plane Stations RDS or Stations Fix.

- Stations RDS (see also page 144)
- Stations Fix (see also page 144)

Storing: 12 frequencies or programmes can be stored per waveband.

In order to store the desired transmitter or programme, press the multifunction button **1 - 6** or **7 - 12** until a signal tone sounds.

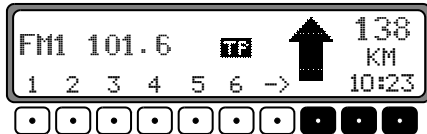

To access memory locations 7 - 12, press the **->** multifunction button.

Request: Press the **1 - 6** or **7 - 12** multifunction button. The stored transmitter is requested.

Requesting/storing MW, LW, SW transmitters

Store: 12 transmitters can be stored under station buttons. Search for the desired transmitter and press the desired multifunction button until a signal tone sounds.

To access memory locations 7 - 12, press the **->** multifunction button.

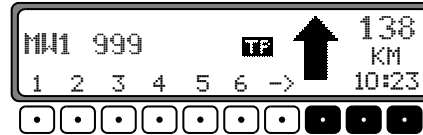

Request: Press the **1 - 6** or **7 - 12** multifunction button. The stored transmitter is requested.

Radio mode

MW, LW autostore

In the desired waveband, press the **Rad** button.



Press the **As** multifunction button repeatedly until Auto store on is displayed.

Press the **As** multifunction button until Seek Autostore is displayed.

The 6 transmitters with the best reception are stored under the station buttons in order of quality.

In order to quit the autostore storage plane, use the multifunction button **As** to switch off the autostore storage plane (off). The radio switches back to the station button plane.

FM manual tuning

In radio menu mode, use the multifunction button **FM** to select the Stations Fix plane.



Press the **Man** multifunction button twice.

Then turn the right rotary control **●**.

100 kHz tuning steps are performed.

On the display, active manual tuning is indicated by **MAN**. After a short delay and without turning the right rotary control **●**, **MAN** disappears and manual tuning is switched off.

MW, LW, SW manual tuning

In the desired waveband, press the **Rad** button.

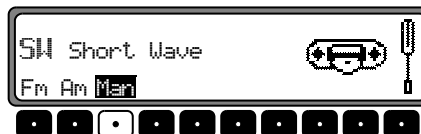

Press the **Man** multifunction button twice.

Then turn the right rotary control **●**.

9kHz (MW), 3kHz (LW) or 5kHz (SW) tuning steps are performed.

On the display, active manual tuning is indicated by **MAN**. After a short delay and without turning the right rotary control **●**, **MAN** disappears and manual tuning is switched off.

Regionalisation

The RDS diversity function is independent of region. If the RDS diversity function should switch among various regional programmes with diverse broadcast contents, the special regional sub-programme must be selected directly.

A transmitter must first be selected in order to see if it broadcasts more than one regional programme.

Transmitters with additional regional transmitters are identified by a star (e.g. 4*).



Upon selection of one of these transmitters (e.g. 4*) all receivable regional sub-programmes for this transmitter will be displayed.

Then select desired regional sub-programme (e.g. **Ka**).



If, despite RDS diversity function, the reception quality of a regional sub-programme is inferior, bear in mind that regional sub-programmes are transmitted for the most part over only a few frequencies. If the unit remains tuned to frequencies with better reception quality, there will be less drift.

Switching regionalisation on/off

Select radio menu mode.



Using the multifunction button **Res** switch the regionalisation on (on) or off (off).

Switching frequency display on / off

Select radio menu mode.



Using the multifunction button **Dis** select either **Fre** quency (frequency display switched on) or **PTY** (frequency display switched off).

Radio mode

Switching radio text display on / off

Select FM radio menu mode. Using the multifunction button

Txt switch on radio text.



The car radio filters information transmitted by the transmitter and displays it in the form of radio text.

Radio text cannot be displayed unless the selected transmitter also transmits radio text.

Unfavourable reception conditions, including interference, can garble or even block a radio text display.

In order to quit the radio text plane, press the **Rad** button.

Note: Since information transmitted via radio text display varies constantly, we recommend tuning in the radio text only when the vehicle is stationary to avoid unnecessary distraction for the driver. This is a necessary precaution for accident prevention.

Traffic Programme (TP)

If an RDS diversity transmitter transmits TP announcements, it is possible to interrupt CD, CDC/AUX, MW, LW or SW operation or the mute function and to switch through the transmitted TP announcement. Moreover, you can listen to one FM station while having TP announcements switched through that are transmitted by another FM station.

The functionality of the traffic programme functions depends on the status of the TMC setting - TMC switched on/off (“Switching TMC on/off” auf Seite 127)

When TMC is switched off:

- There are two ways to select a TP transmitter:
 - **automatic tracking**
 - **direct programming**

Automatic tracking always uses the FM station currently being received as the TP transmitter. If the selected FM station has poor reception quality or cannot function as a TP transmitter, the unit applies specified criteria to search for a new TP transmitter.

Direct programming enables a TP transmitter to be programmed that is not the FM station being received. For example, one FM station can be received while TP announcements transmitted by another FM station are switched through.

If the programmed TP transmitter reception is poor, the unit switches to automatic tracking until the programmed TP transmitter is receivable.

When TMC is switched on:

- With TMC, the unit is capable of selecting a suitable traffic programme transmitter automatically. If possible, a TMC station is selected as the traffic programme transmitter. The selected TMC station usually offers the best traffic information for the region in which you are travelling. If no TMC station is available, the traffic programme transmitter with the strongest signal is selected.

If an RDS transmitter is equipped with a traffic programme, this is indicated on the display by TP.

An inverse TP TP appears on the display to indicate that the traffic programme is active.

Activating/quitting the TP menu

Activating: Press the TP button (traffic announcements cannot be transmitted).



Press the TP multifunction button.

Quitting: Press the TP button or the TP menu will be automatically terminated after 8 seconds without actuation.

Switching TP on/off

In all modes and wavebands, TP can be switched on/off by pressing the TP button for more than 2 seconds.

TP can also be switched on/off in the TP - menu.

Switching on: To switch on TP in the TP menu, press the TP multifunction button repeatedly until TP on is displayed.



Switching off: To switch off TP in the TP menu, press the TP multifunction button repeatedly until TP off is displayed.



TP is switched off after returning to normal display.

Radio mode

Selecting automatic tracking

Only applies when **TMC is switched off**.

In all modes and wavebands, automatic tracking can be switched on by pressing the **TP** button for more than 2 seconds.

To switch on automatic tracking in the TP menu, press the **TP** multifunction button repeatedly until TP on is displayed.



Attention: If a TP transmitter has already been programmed directly, it will once again be selected as the TP transmitter.

Selecting / deleting direct programming

Only applies when **TMC is switched off**.

Activate the TP menu.

Selecting: Press the **Sta** multifunction button.



Using the right rotary control, select the desired TP transmitter. After a short delay and without actuation, the

selected transmitter is accepted.

Deleting: Press the **Sta** multifunction button.



Using the right rotary control, select **Autoselect** and press to confirm. After a short delay and without actuation, the direct programming is deleted. Quit the TP menu.

Switching mute on/off

After selecting a TP or EON transmitter, the mute function can be activated by briefly pressing the **TP** button.



Thereafter, only traffic announcements and navigation announcements will be switched through. After pressing the **TP** button again, muting is cancelled.

Interrupting TP announcements

During a TP announcement, briefly press the **TP** button. The announcement currently being broadcast will be interrupted and the system will automatically return to the previously selected mode.

TP announcement volume

Activate the TP menu. Press the **Vol** multifunction button.



Using the right rotary control , four different settings (0 - 3) can be selected. This means that the volume can be raised to a fixed value according to the setting.

- Setting 0 - no volume increase
- Setting 1 - slight volume increase
- Setting 2 - medium volume increase
- Setting 3 - large volume increase

Switching TMC on/off

Note: You can find further information on TMC under “Dynamic navigation with TMC” auf Seite 101.

Activate the TP menu.



Switching on:

Press the **Tmc** multifunction button repeatedly until TMC on is displayed.

If TMC is switched on, a traffic programme transmitter cannot be selected freely. A TMC station is selected by the unit, provided one can be received. This transmitter then corresponds to the traffic programme transmitter.

Switching off:

Press the **Tmc** multifunction button repeatedly until TMC off is displayed.

If TMC is switched off, a traffic programme transmitter can be selected freely.

Note: Dynamic navigation functions (dynamic route, traffic information) cannot be selected or called up.

Radio mode

Display for TMC stations

If a radio station transmits TMC information in addition to the radio programme, this is indicated on the display by the abbreviation TMC. TMC information is received and analysed by the navigation system. The reception of traffic announcements is free of charge.

TMC is shown in **normal typeface**:

The instantaneously selected station is a TMC station. TMC is switched off.

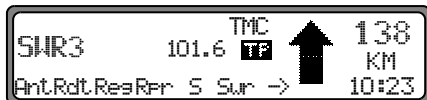

TMC is shown in **inverted typeface**:

The instantaneously selected station is a TMC station. TMC is switched on.



Telephone mute function

The telephone characteristics can be set in the user menu (page 136) if a telephone system is installed in the vehicle and the mute function lead for the car telephone is connected to the car radio.

If **MUTE** is selected, the radio is switched to mute if a call is received.

If **audio signal** is selected, the telephone call is connected through the radio unit if a call is received (vehicle ignition must be switched on).

However, this is only possible if, in addition to the telephone, a handsfree unit with loudspeaker output is installed and connected to the radio. In both cases, **PHONE** is displayed.

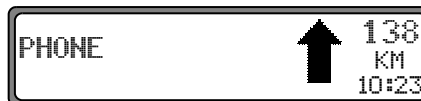

Compact Disc (CD) instructions

Sound interruptions may occur if the CD is dirty. In order to ensure optimum tone quality, please note the following:

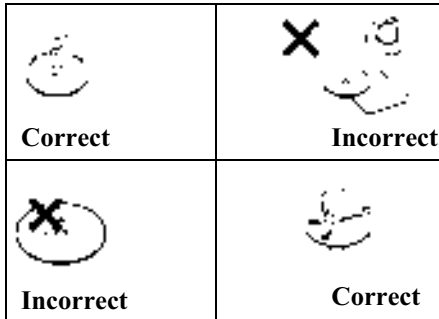

- Always touch the CD at the edges only. Keep the disc clean and never touch the surface.
- Never stick anything to the CD.
- Protect the CDs against direct sunlight and from heat sources such as heaters etc.
- Before playing, clean the CD with a commercially available cleaning cloth, wiping from the centre outwards. Solvents such as petrol, thinners or other commercially available cleaners and anti-static sprays must not be used.



Inserting / ejecting CDs

Press and hold  button; the display folds downwards and the CD slot becomes visible. Insert the disc into the CD slot with the printed side upwards. The unit pulls in the CD automatically and begins to play the disc from the first track. Then fold the display up again.

After playing the last track, the unit automatically begins to play the first track of the CD again.

If there is already a CD in the slot, press the  button. If CD changer / AUX operation was last selected, use the multifunction button  to switch to CD operation.



To eject a CD, press and hold  button; the display folds downwards and the CD is ejected. Remove the CD. Then fold the display up again.

Attention : The CD is not ejected when the unit is switched off but remains in the CD slot.

CD mode

Track skip - forwards / backwards

Press the multifunction button  (forwards) or  (backwards).



By pressing the multifunction button repeatedly, several tracks can be skipped over in forward or reverse directions. The unit switches to the first track when the last track has been reached. Analogously, it switches from the first track to the last track.

If the track has been playing for longer than 10 seconds when the track skip function is triggered, the device returns to the beginning of the track.



Scan search

Press the right rotary control , SC appears on the display.



All following CD tracks are played for 10 seconds each. Press the right rotary control  again to terminate the scan search.

Fast forward / rewind

By pressing the multifunction button  (audible) fast forward is activated, or by pressing the multifunction button  (audible) fast rewind is activated.



Fast forward / rewind is terminated by releasing the multifunction button.

Random play

By pressing the multifunction button  random play is activated. The tracks on the current CD are then played in random order. The prompt Rnd is displayed inversely.



After pressing the multifunction button  again, the random play function is deactivated.

Repeating a track

By pressing the multifunction button **RPT** the track repeat function is switched on. The prompt **RPT** is displayed inversely.



After pressing the multifunction button **RPT** again, the track repeat function is switched off.

Number of tracks and total playing time

In CD mode, press the **CD** button. By pressing the multifunction button **Trk** the elapsed time for the tracks already played is displayed briefly.



By pressing the multifunction button **Ttl** the number of tracks and the total playing time of the current CD are displayed briefly.

Temperature protection circuit

A temperature protection circuit is utilised in this unit in order to protect the laser diode against overheating.

When the protection circuit is requested, **TEMP** is displayed for 8 seconds and the unit switches back to radio operation.

The single CD operation can be requested again after a short cooling phase. However, if the temperature is still too high, the unit again switches back to the previously selected signal source.

CD changer operation

Operational readiness of CD changer

If a CD changer is connected to the car radio, it is ready for operation when loaded with a full CD magazine. Close the sliding tray after loading. Further operation is performed via the car radio control panel.

CD magazine - load / unload

To remove the CD magazine, open the sliding cover on the changer and press the eject button. The magazine is ejected and can be removed.

When inserting CDs in the magazine, please note imprint on magazine.

Attention : Incorrectly inserted CDs will not be played.

Note: In order to ensure the fastest possible CD change, the magazine should be fully loaded from compartment 1.

Playing CDs

Press **CD** button. If the unit was last set to CD changer operation or there is no CD (or navigation CD) in the CD drive, the CD changer menu is now active.

If CD operation was last selected, use the multifunction button **CD** to switch to CD changer operation.

The last CD to be played is played from the position at which it was left before switching off.

Stored CDs can be selected by turning the right rotary control **CD**. Loading CD X is displayed during the selection time. The magazine compartment number or the name of the CD and the number of the current track on the selected CD are then displayed.

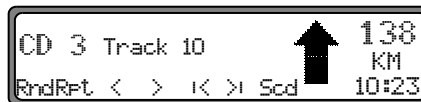

If no CD is present in the selected magazine compartment (e.g. compartment 2), NO CD 2 is displayed briefly.

After playing the last track of a CD, the next CD is automatically selected and played.

For further operation, see under CD mode (Page 129):

- "Compact Disc (CD) instructions" on page 129
- "Track skip - forwards / backwards" on page 130
- "Scan search" on page 130
- "Fast forward / rewind" on page 130
- "Random play" on page 130
- "Repeating a track" on page 131
- "Number of tracks and total playing time" on page 131

Naming a CD

In CD changer mode, press the **CD** button. Then press the **Nam** multifunction button.



To enter a name or change an existing name, press the multifunction button **Edt**.



Using the multifunction buttons **<-** and **->** select the desired position (inverse editing symbol).



Using the right rotary control **●**, select the desired letters and press to confirm.

Press the right rotary control **●** to move one place further.

A maximum of 8 characters can be entered. The name is stored after quitting the CDC menu.

To delete an existing name, press the **Nam** multifunction button.

Using the right rotary control **●**, select the name to be deleted.



The name can be deleted by pressing the **Del** multifunction button.

CD changer operation

CD filter function

In CD changer mode, press the **CD** button. Then press the **Fil** multifunction button.



For the Silverstone 2660 CD changer, the individual tracks of the current CD can be selected using the right rotary control **▶**. It is then possible to select between **Play** (track not filtered) and **Skip** (track filtered out) by pressing the right rotary control **▶**.

In order to switch the filter function on or off, repeatedly press the multifunction button **Fil**. The filter function is switched on (**Fil on**) or off (**No Fil**).

For the Silverstone 2630 and 2640 CD changers, it is possible to select between **Play** (track not filtered) and **Skip** (track filtered out) for the current track by pressing the right rotary control **▶**.

Attention : The filter function can only be activated if a name has been stored for the selected CD.

Requesting/quitting user menu

After requesting the user menu, the following basic settings can be selected on two planes according to your personal preference.

First plane:

- Gal - speed-dependent volume control
- Tel - telephone characteristics
- Col - display colour setting
- Lcd - display setting
- Led - LED setting
- M/S - reception optimisation setting

Second plane:

- Nav - navigation announcement setting
- Aux - aux input setting
- Cmp - compass display setting
- BeU - signal tone volume setting

The user menu is requested by pressing the  button for more than 2 seconds.





In order to access the second plane of the user menu, press the  multifunction button.

Press the  button again to quit the user menu.

GAL setting (Gal)

The GAL is a car radio control circuit, which automatically adjusts the car radio volume according to vehicle speed. This results in compensation of the driving noise produced at higher speeds.

Request the user menu. Press the  multifunction button. Using the right rotary control  select either 0 or +15.



With the GAL setting, the start of volume adjustment can be specified according to vehicle speed.

The setting is stored automatically.

Explanation:

- 0 - no volume increase
- +1 - volume is increased at low speed
- +15 - volume is increased at a higher speed

User menu

Telephone mute characteristics (Tel)

If a telephone system with handsfree unit is installed in the vehicle, the telephone conversation can be conducted via the car radio system. Thus, installation of the additional loudspeaker which is normally required is not necessary. However, the signal cables (AF - telephone input and earth - telephone input) must be connected to the car radio (see page 146).

For selection, request user menu. By pressing the multifunction button **Tel** select either `audio signal` or `mute`.

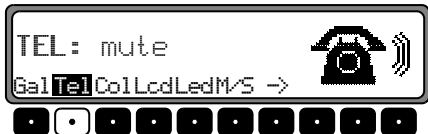

- `mute` - Telephone mute mode
- `audio signal` - Telephone conversation via car radio

Display colour setting (Col)

This setting is used to choose between two illumination colours (not possible for all versions).

For selection, request user menu. By pressing the multifunction button **Col** select either `red` or `yellow`.

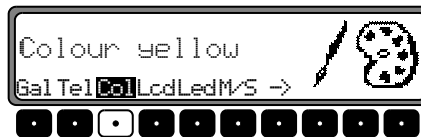

The setting is stored automatically.

Display setting (Lcd)

The display setting allows you to select among three different display versions.

- Negative display (`nesative`)
- Positive display (`Positive`)
- Automatic display (`automatic`) - the display will appear negative or positive depending on vehicle illumination.

For selection, request user menu. By pressing the multifunction button **Lcd** select either `nesative`, `Positive` or `automatic`.



The setting is stored automatically.

Setting reception optimisation (M/S)

Three different reception optimisation settings can be selected in order to suppress reception-dependent interference and reflections.

Request the user menu. By pressing the multifunction button **M/S** select either **Stereo**, **Mono** or **Auto**.



- **Auto** - Setting for normal operation - i.e., the system switches from stereo to mono and back depending upon reception location (provides the optimum setting for almost all reception areas).
- **Stereo** - Setting for exceptional reception conditions - i.e. the unit is constantly set to stereo.
- **Mono** - Setting for reception conditions in which reflections constantly occur - i.e., the unit is set constantly to mono.

The setting is effective immediately and is also retained on switching off.

LED setting (Led)

The flashing of the LED (flashes when unit is switched off) can be switched on or off using this function.

Request the user menu. By pressing the multifunction button **Led** select either **blinking** (LED switched on) or **off** (LED switched off).



The setting is stored automatically.

Setting navigation announcements (Nav)

With this function you can select how you wish to hear navigation announcements.

- **only** - The audio source currently being listened to is switched off and only navigation announcements are heard.
- **mixed** - The volume level of the audio source currently being listened to is decreased. The navigation announcement is set to the same volume level as the previously heard audio source but still adjustable within a range of +/-6 dB. If the audio source volume is then changed, the navigation announcement volume is adjusted accordingly.
- **independ** - The audio source being listened to and the navigation announcement can be set to various levels.

User menu

For selection, request user menu. By pressing the multifunction button **→** request the second plane of the user menu. Using the multifunction button **Nav** select either **only**, **mixed** or **independ**.



The setting is stored automatically.

AUX input (Aux)

This can be used to switch on the CD changer AF connections if no CD changer is connected. An external unit (Discman, Walkman, etc.) can then be connected.

For selection, request user menu. By pressing the multifunction button **→** request the second plane of the user menu. Using the multifunction button **Aux** select either **AUX mode on** (on) or **Aux mode off** (off).



The setting is stored automatically.

In CD mode, press the **Aux** multifunction button in order to select AUX mode.

Compass display (Cmp)

When the Navigation is not active, it is possible to have a compass and the current time shown on the right side of the display.

For selection, request user menu. By pressing the multifunction button **→** request the second plane of the user menu. Using the multifunction button **CMP** select either **show COMPASS** (compass is displayed) or **hide COMPASS** (compass is not displayed).



If the compass display is switched off, 9 multifunction buttons are assigned transmitter abbreviations in FM - DAS mode (route guidance not active).



The setting is stored automatically.

Signal tone volume (BeV)

the volume of signal tones (e.g. storage confirmation) can be set using this function.

For selection, request user menu. By pressing multifunction button  request the second plane of the user menu. Press the  multifunction button. Using the right rotary control  select either 0 (quiet) or +5 (loud).



The setting is stored automatically.

Service menu

Requesting /quitting the service menu

The following information can be requested from the service menu.

- **Model no.:** - display of model number
- **Serial no.:** - display of serial number
- **Changer Reset** - reset triggering for CDC (if present).
To reset, press **Res** multifunction button.
- **GAL** - display of current GAL setting
- **Radio Software** - display of radio software status
- **Radio Bolo** - display of radio bolo status
- **Navi Rom** - display of navi rom / lib status
- **Navi Flash** - display of navi flash status
- **RTC Value** - display of RTC value

In order to select the service menu, press the **Nav** and the 10 multifunction buttons simultaneously in radio mode.

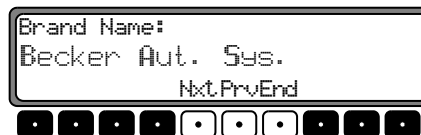

Using the multifunction buttons **Nxt** and **Prv** or by turning the right rotary control **⦿**, the individual items can be selected.

In order to quit the service menu, press the **End** multifunction button.

Triggering reset

If a malfunction of the unit should occur, such that the unit is no longer capable of operation or is defective in some other way, a restart of the internal unit software (reset) can be triggered via the following button combination.

In order to trigger a reset, press the **1**, or the **3** multifunction buttons and the **TP** button simultaneously.

The navigation CD must be inserted after a reset of the unit software.

Connection instructions

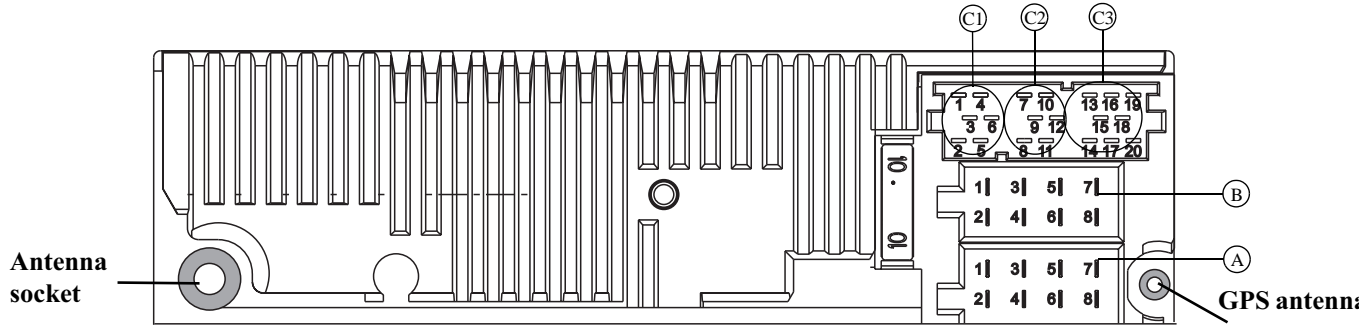

Warning! Terminal 30 and terminal 15 must always be connected separately, otherwise excessive current consumption occurs when the unit is switched off. Connection socket A is not the same for all vehicle types. Therefore, always measure voltages before installation.

Socket A

- 1 Speed signal (GAL)
- 2 Reversing lamp signal
- 3 Telephone mute / clearing function
- 4 Permanent positive (terminal 30)
- 5 Control output for automatic antenna/amplifier
- 6 Illumination (terminal 58)
- 7 Switched positive (terminal 15)
- 8 Earth (terminal 31)

Socket B

- 1 Loudspeaker rear right +
- 2 Loudspeaker rear right -
- 3 Loudspeaker front right +
- 4 Loudspeaker front right -
- 5 Loudspeaker front left +

- 6 Loudspeaker front left -
- 7 Loudspeaker rear left +
- 8 Loudspeaker rear left -

Socket C1

- 1 LineOut rear left
- 2 LineOut rear right
- 3 AF earth
- 4 LineOut front left
- 5 LineOut front right
- 6 Subwoofer LineOut

Socket C2

- 7-12 Special connection for Becker CD changer

Socket C3

- 13 AF telephone input
- 14 Earth - telephone input
- 15-17 Special connection for Becker CD changer
- 18 CD AF earth (AUX)
- 19 CD AF left (AUX)
- 20 CD AF right (AUX)

Removal / installation guide

A universal bracket for DIN installation slots is integrated into this car radio. An installation frame is not required. The unit is inserted into the installation slot and secured with the slides supplied.

Complete the electrical connections. Then push the unit into the installation slot. Subsequently, push the slides into the apertures in the front of the unit to the first detent position (Figure A). Now lock the radio by pulling both slides, as shown in Figure B. Subsequently, remove the slides.

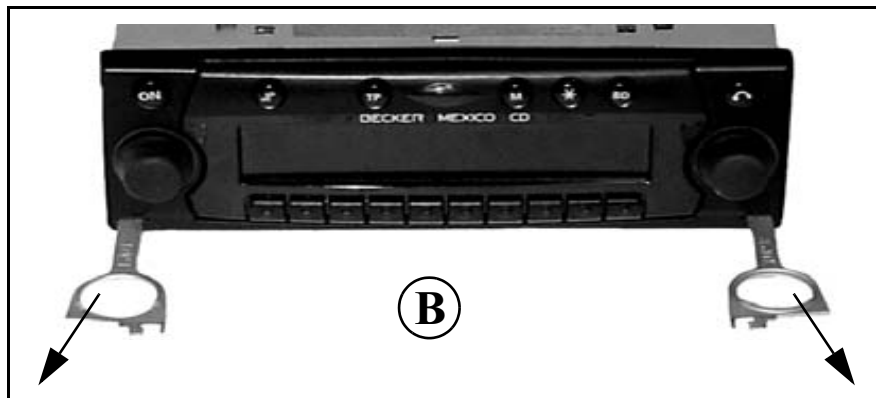
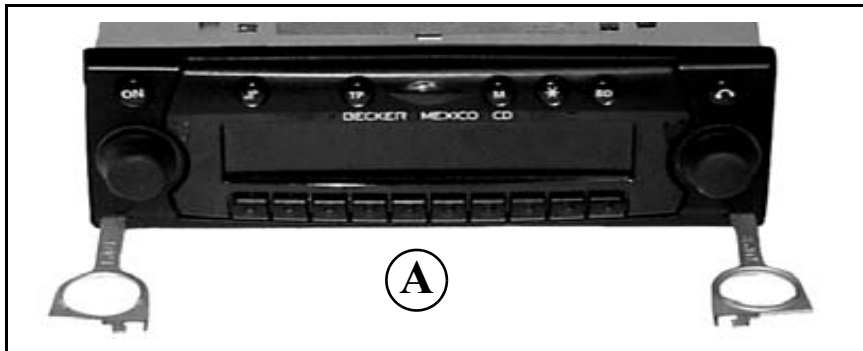

Removal / installation guide

For removal, the unit must first be unlocked. For this purpose, push in both slides to the second detent position, as shown in Figure A. Subsequently, withdraw the unit with both slides. (Figure C). Then remove the slides by pressing the springs on the right and left sides of the unit.

If the unit has been installed in another vehicle, the unit's springs may have to be adjusted before installation. To adjust the springs, push in the slides as shown in Figure D and then adjust as shown in Figure E (press the slide lightly in direction 1 and simultaneously move the slide in direction 2).

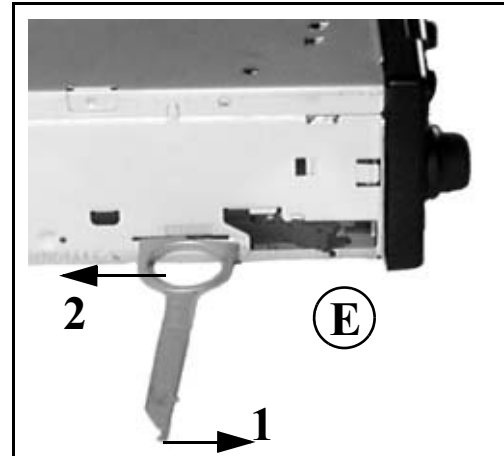
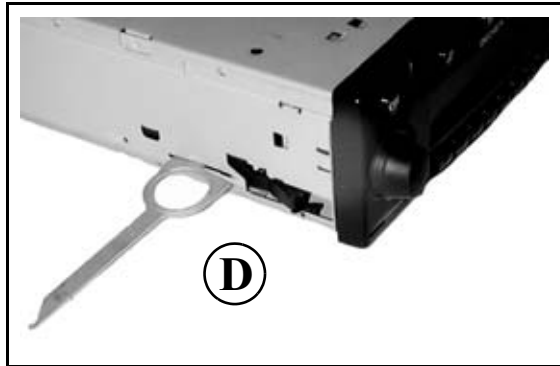

General instructions

RDS SYSTEM

This car radio is capable of receiving RDS signals (RDS = Radio Data System) in the VHF range. RDS is a technique which enables the transmission of inaudible additional information in the VHF broadcasting range. This means that the transmitter broadcasts information which can be evaluated by the car radio.

DAS Seek Qual. plane

In the *DAS Seek Qual.* plane, all receivable and identifiable RDS programmes are arranged in a list according to quality. The dynamic autostore, search and scan search functions fall back upon this list.

DAS Seek Name plane

In the *DAS Seek Name* plane, all receivable and identifiable RDS programmes are alphabetically arranged in a list according to name. The dynamic autostore, search and scan search functions fall back upon this list.

Stations RDS plane

In the *Stations RDS* plane, only identified RDS stations can be stored. The unit constantly switches to the best receivable transmission frequency for the station.

During the search on *Stations RDS* the unit only stops at identifiable stations.

Stations Fix plane

In the *Stations Fix* plane, frequencies can be assigned to the station buttons. RDS evaluation does not take place. The search on *Stations Fix* is applicable to FM manual tuning (page 122).

PTY (Programme Type)

Specific types of programme, such as e.g. sport, pop music, classical music etc., can be selected using the PTY function.

The PTY is broadcast by the RDS transmitter, provided that the transmitter is equipped with this function. The selected transmitter programme type can be displayed or a search for a specific PTY transmitter can be performed.

Examples of programme types are:

NEWS	News services
POP M	Pop music
AFFAIRS	Politics and current affairs
ROCK M	Rock music
INFO	Special word programme
SCIENCE	Science
EDUCATE	Learning and further education
LIGHT M	Light music
DRAMA	Radio plays and literature
CLASSICS	Classical music
CULTURE	Culture, church and society
EASY M	Easy listening
VARIED	Light entertainment
SPORT	Sport
OTHER M	Special music programmes
WEATHER	Weather report
FINANCE	Financial information
CHILDPRG	Children's programmes
SOCIAL	Social reports
RELIGION	Religious reports

PHONE IN	Interviews
TRAVEL	Travel reports
LEISURE	Leisure reports
JAZZ	Jazz music
COUNTRY	Country music
NATION M	National folk music
OLDIES	Oldies
FOLK	Folk music
DOCUMENT	Documentaries
NO PTY	No PTY

Technical data

Wavebands	:	FM 87.5 MHz - 108 MHz MW 531 kHz - 1620 kHz LW 153 kHz - 282 kHz SW 5800 kHz - 6250 kHz
Frequency range	:	20 Hz - 20 kHz for CD operation 30 Hz - 15 kHz for FM 50 Hz - 2.5 kHz for MW, LW, SW
Output power	:	4 x 18 Watt
Line cross section	:	min. 0.75 mm ²
Loudspeaker impedance	:	min. 4 Ω
Line out	:	4 x analogue line out (V _a max 3V _{eff} at 10 kΩ)
GAL	:	In order to utilise the GAL, a square wave voltage with an amplitude of +4 V - +12 V relative to earth, must be available from the electronic speedometer of the vehicle. The adjustment is performed in 7 steps of 2.5 dB.
Aerial	:	Impedance 50 Ω
AF telephone input	:	Max. input voltage 8 V (if interference occurs, a commercially available 1 : 1 transformer should be connected into the signal cable).
AUX input	:	16 kΩ input impedance, max. input voltage 1.7 V _{eff}
Telephone mute	:	Low active level < 2 Volt
Supply voltage	:	12 V
CD connection	:	The Becker Silverstone 2630 and Silverstone 2660 CD changers can be connected.
Playable CDs	:	Only CDs which conform to DIN EN 60908 may be used. The use of 8 cm CDs with adapter is not recommended.

NOTICE

Dear listener,

In conformance with current EC guidelines, any person may operate this radio receiver.

This unit conforms to the current valid European or harmonised national regulations. The designation is your guarantee of conformance to the applicable specifications concerning electromagnetic compatibility for the unit. This means that interference affecting other electrical/electronic devices caused by your unit, as well as interfering influences on your unit from other electrical/electronic devices, can be largely prevented.

Current valid designations are:

- **CE symbol** for issue according to European guideline 89/336/EEC under application of the following standards:
 - EN 55013
 - EN 55020

- **e symbol** according to European motor vehicle EMC guideline 95/54/EU, also permits operation in motor vehicles (classes M, N and O) which received their type approval after 1st January 1996.



021473